

## PIN CARRIER APPLICATION INSTRUCTIONS 2 ROW

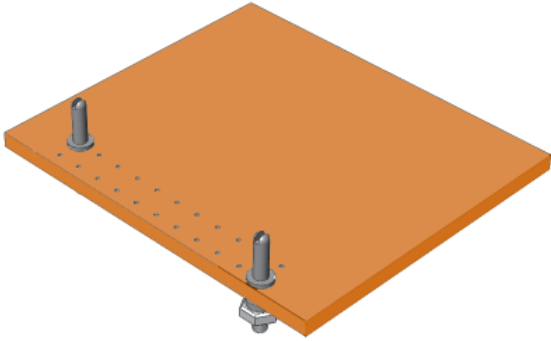

1. INSTALL GUIDE PINS ON PRINTED WIRING BOARD. ASSEMBLE NUTS "FINGER" TIGHT ONLY.

2. POSITION THE LOADED PIN CARRIER ONTO THE BOARD, USING THE GUIDES FOR ALIGNMENT. TORQUE NUTS ON GUIDE HARDWARE. THEN SOLDER THE CONTACTS ON UNDER SIDE OF BOARD.

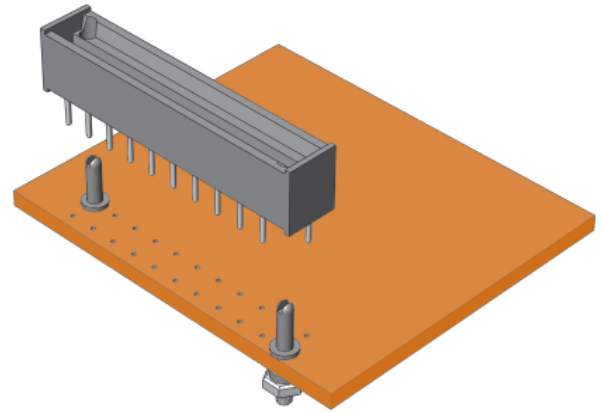

3. CARRIER MAY NOW BE REMOVED FOR MATING WITH A RECEPTACLE OR LEFT IN PLACE AS A PIN PROTECTOR.

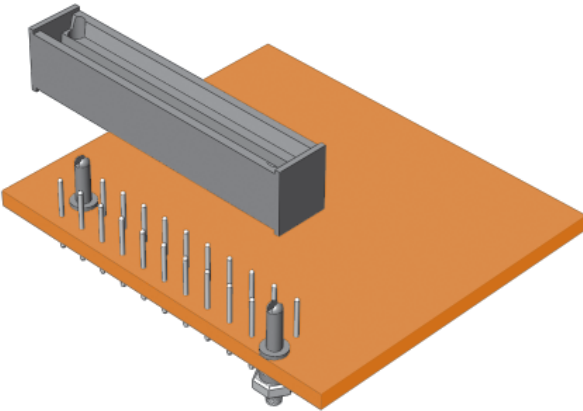

4. WHEN MATED WITH A RECEPTACLE, ASSEMBLY CAN BE COMPLETED IN THE LEAST AMOUNT OF SPACE (.240 INCHES).

